

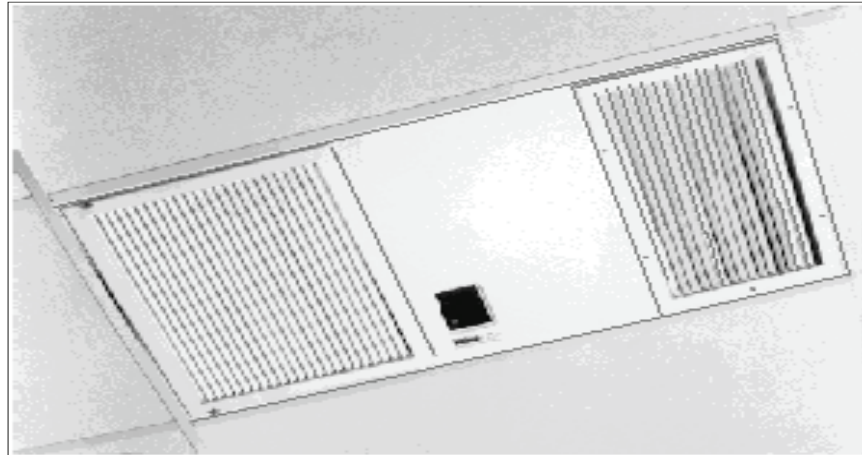

Operating and Service Instructions Model LAFC
120V or 230V
Model HEPA LAFC 120V or 230V



Self Contained – Flush Ceiling Mounted Electronic Air
Cleaner – LAFC
HEPA Media Air Cleaner – HEPA LAFC



RK Ventures Inc. Racine,wi
1509 Rapds Drive
www.lakeair.com

TABLE OF CONTENTS

Introduction _____	3
Providing Clean Fresh Air _____	3
Energy Consumption Is Lower _____	3
Recirculated Air for Comfort and Savings _____	3
Components of the LAFC and HEPA LAFC _____	4-5
How Your LAFC Model Works _____	5
Installation Instructions _____	6-7
Important Safety Instructions _____	6
Equipment Needed for Installation _____	6
Items Supplied as Loose Parts _____	6
Unpacking _____	6
Preparation for Mounting _____	6
Mounting _____	6
Installation of the Electric Wiring _____	7
Reassembly of the Unit _____	7
Exhaust Grille Orientation _____	7
Start-Up and Checkout of the Unit _____	7
Maintenance and Service – LakeAir Model LAFC	
General Information _____	8
Application _____	8
Sizing _____	8
Maintenance _____	9
Washing the Electric Cells and Prefilter _____	9
Replacing the HEPA Media Pad _____	9
Service _____	9
Troubleshooting Guide and Chart _____	10-11
Diagnostic Checks _____	10
Powering Up the LAFC _____	10
Test Technique _____	10
Cell Check _____	10
Check Power Supply _____	10
Component Checks _____	11
Check Fan Motor and Power Source _____	11
Check the Electronic Cell _____	11
Check for Short Circuits _____	11
Check Transformer and Voltage Doubler _____	11
Troubleshooting Flowchart _____	12
Electrical Connections _____	13
Electrical Schematic _____	14
LakeAir Electronic Air Cleaners 7 Year Limited Warranty _____	15
User’s Responsibility _____	15
Model LAFC Parts Schematic _____	16

OWNER'S MANUAL

Introduction

Your LakeAir Model LAFC is a self-contained ceiling mounted electronic air cleaner. Model HEPA LAFC uses a high efficiency non-electric media. They are designed for installation in a standard T-Bar ceiling in the space occupied by a 2 x 4 drop ceiling panel. Each unit is equipped to deliver very high efficiency and trouble free operation.

Providing Clean Fresh Air

Each day an individual breathes in at least 16,000 quarts of air. That air is filled with particles of smoke, dust, pollen, microorganisms, and other pollutants. With your new LakeAir Electronic or HEPA air Cleaner, you and your customers will breathe air which is relatively free of those pollutants. Today the emphasis is on health and well being, and by using your LAFC you will see a direct benefit to your business.

Energy Consumption Is Lower

The exhausting of polluted air to the outside is the most common solution to the removal of concentrations of polluted air. In doing so, however, you must also bring supplies of fresh air to take the place of the air ex-hausted. You must also heat or cool this air to make it comfortable for the occupants of the space involved. This can be expensive, but with your LakeAir brand Air Cleaner, you will drastically reduce the need for out-side air by recirculating the indoor air and thereby reducing your heating and cooling costs.

Recirculated Air for Comfort and Savings

With the use of your LakeAir brand Air Cleaner, you will find that bothersome smoke and other small particles which settle out on walls, curtains, glasses, bottles, mirrors, and other surfaces will be substantially reduced or eliminated, thus saving you costly maintenance and redecorating.



Easy access filter cell/HEPA filter in drop-down door.

COMPONENTS OF THE LAFC AND HEPA LAFC

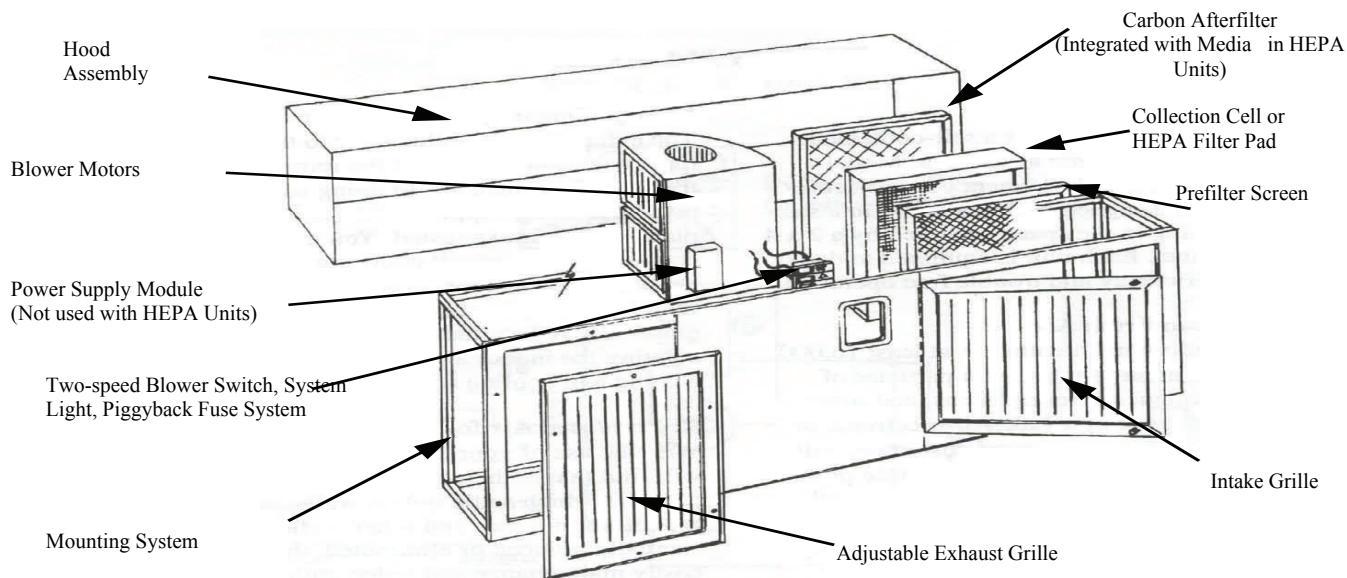

Hood Assembly

The LAFC is fitted with a corrosion resistant galvanized steel hood which requires only 11.25" of space above the drop ceiling for installation.

Mounting System

The LAFC is equipped with a steel inner frame that has four drilled and tapped 1/4 x 20 holes for the provided eye bolts or for the use of threaded rod, to mount the unit to the superstructure above for a safe and secure installation HEPA LAFC units.

Intake Grille

A fixed position intake grille allows for even distribution of the incoming air over the cleaning surface. The grille and the inner steel hinged frame swing open for easy access to the filter.

Pre filter Screen

An aluminized pre filter screen is provided to collect large particles such as lint and hair. It is easily removed for cleaning with water and mild soap. This filter helps keep your electronic filter cell or HEPA media cleaner for a longer length of time.

Electronic Collection Cell

The Electronic Model LAFC uses one large collection cell positioned behind the pre filter screen which collects the majority of the air-borne particles that enter the system. **HEPA Pad Media and Carbon Afterfilter** Carbon afterfilter is standard with all LAFC units, and is used to remove odors from the air. It is integrated with the HEPA filter pad **Power Supply Module (Electronic Only)** The patented LakeAir power supply has been used in thousands of LakeAir EAC's of all sizes. It is the only power supply in the industry which is guaranteed for seven years. It delivers a constant regulated Voltage to the collection cell.

Blower Motor

Your LAFC is equipped with a powerful yet quiet motor-driven blower type fan which is calibrated for two speeds of operation. The grommated suspension system eliminates chances for vibration.

Adjustable Exhaust Grille

Large adjustable exhaust grille with individually adjustable vanes allows a variable air-flow to be presented to the room according to size and traffic pattern.

Safety Interlock System

Located in the channel behind the collecting cell, the micro-switch controlled interlock system will not allow operation of the LAFC without having the intake panel locked into place.

Two-Speed Fan Switch

Your LAFC is equipped with a three-position switch that allows for *High* and *Low* fan speed as well as a center *off* position. The electronic collection system and the fans are designed to run simultaneously.

System Light

The LakeAir LAFC is fitted with a system light which indicates when your air cleaner is in operation. Located below the three-position switch, the light will be lit when all system connections are activated.

Piggyback Fuse System

The unit is provided with a fused circuit that protects valuable components in case of a power surge. An additional "piggyback" fuse is located in the fuse holder for easy access if it is needed.

HOW YOUR LakeAir MODEL LAFC WORKS

In business establishments or public buildings, millions of airborne particles are continually being circulated in the air you breathe. Your LakeAir Model LAFC Self Contained Flush Mounted Electronic Air Cleaner removes the smoke, dust, dirt, pollen, and other pollutants from the air with an electrostatic process which works this way:

1. The internal circulating blower mechanism draws the dirt laden air into the system where it first encounters the outer PREFILTER SCREEN.
2. The PREFILTER SCREEN collects the larger particles from the air and holds them on its intermeshed surface.
3. In electronic units, the air then passes into the ELECTRONIC FILTER CELL where it first meets the IONIZING SECTION with its many fine ion wires. These wires charge the airborne particles by exciting them with a high electrical charge. As the charged particles move along to the COLLECTING SECTION, they are trapped by the collector plates much like a magnet attracts and collects metal filings.
4. In HEPA LAFC units, the air is drawn through a high efficiency, hospital grade media pad. The harmful particles are trapped and held by the closely spaced fibers.

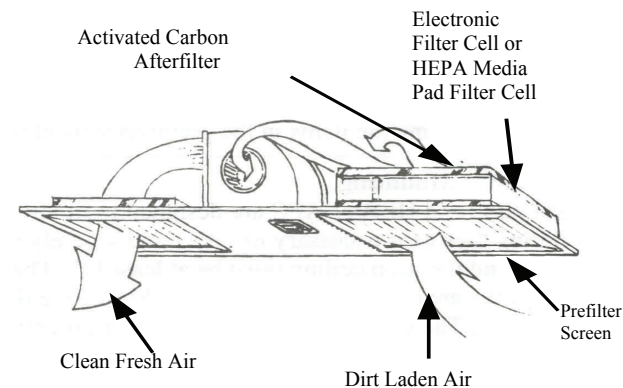

5. The ACTIVATED CARBON AFTER-FILTER, the final filter in the system, removes odors and freshens the air.
6. The cleaned and purified air is then returned to the room environment.

INSTALLATION INSTRUCTIONS

IT IS IMPORTANT TO READ THE FOLLOWING INSTRUCTIONS CAREFULLY. DAMAGE TO THE PRODUCT OR TO INSTALLER AND PROPERTY COULD RESULT IF INSTRUCTIONS ARE NOT FOLLOWED.

Important Safety Precautions

1. Do not connect the power source until after the unit is mounted. Shock and/or damage could result.
2. Be sure to shut the unit off prior to any service work.
3. Wear gloves to protect hands during installation as well as to keep the surface of air cleaner free from dirt and smudges.

Equipment Needed for Installation

1. Regular and Phillips Screwdrivers
2. Wire cutters
3. Pliers
4. Twelve gauge galvanized wire for hanging the wires from the true ceiling to the top of the unit (if threaded rod is to be used, it will replace the wire.).
5. Enough twelve or fourteen gauge electrical wire and conduit to reach the nearest switched circuit. (see Electrical Instructions)
6. Junction box fittings as required.

Items Supplied as Loose Parts

1. Four (4) black 1/4 x 20 eyebolts

Unpacking

1. Remove unit from carton and turn over so that grille surfaces are accessible.
2. Remove pre filter and collection cell or HEPA pad from unit through intake side of cleaner. This is accomplished by turning the access screws and lifting the hinged opening. The electronic filter cell is attached by a black grid cap connector on the side of the cell.
3. After removing the items in the previous step, close and lock the hinged intake panel.

Preparation for Mounting

The LAFC and HEPA LAFC are designed to fit into a T-bar drop ceiling. Remove as many of the 2 x 4 ceiling tiles as is necessary to safely and securely mount the air cleaner. The area between the true ceiling and the drop ceiling must be at least 11". There must be no duct work, pipes, or other obstructions to the area where the unit is to fit. Make sure that the spot chosen will be oriented for good air circulation. The exit grille can be adjusted for different airflow patterns by turning the individual vanes.

Mounting

1. Attach four (4) 12 gauge galvanized steel support wires to the true ceiling. Twist each wire at least four times to provide for safe support for the air cleaner. Make sure the free end of the wire extends far enough to adequately reach the eyebolts and be attached to them.
2. Turn the air cleaner onto the grille portion so that the four holes are visible on the top portion of the unit. Attach the four eyebolts to the top by screwing them into the appropriate holes.
3. Lift the air cleaner into place and rest on the T-Bar opening without putting weight upon the T-Bar grid work. The weight should be borne by the support wires with the T-Bar acting as holding receptacle for the unit facing. You should check the level of the unit to insure proper operation.

a

Installation of the Electrical Wiring

Caution: This procedure should only be attempted by persons qualified to install electrical wiring.

All wiring must comply with applicable codes and ordinances.

1. Locate a 120V AC, 60 Hz (alternative power sources would be used in the case of the LAFC 230V units) power circuit with a junction box near the air cleaner location.
2. Check that the circuit breaker or fuse, for that circuit is rated at 15 amperes or 20 amperes. The required copper wire size will be:

AWG #14 for 15 ampere circuits
AWG #12 for 20 ampere circuits

3. Caution: Turn off the building circuit at the fuse or circuit breaker before proceeding.
4. Locate the connection box on the air cleaner and remove the outer plate which contains the knockout. You will note the presence of three wires on the inside of the box. One blue, one brown, and one green.
5. Connect the blue and brown wires from the pigtails in the air cleaner, to the corresponding colors in the supply circuit. (See diagram on page 13.)
6. Connect green wire from the grounded terminal in the air cleaner, to the grounded circuit of the building wiring system. If the building does not have conduit it will have a green or bare ground-ing conductor for connection to the air cleaner green wire. **DO NOT CONNECT THE GROUNDING WIRE FROM THE AIR CLEANER TO THE WHITE WIRE OF THE BUILDING.** The air cleaner frame must be electrically connected to the frame of the building or the electrical conduit system. Input electrical power should be run through flexible conduit as recommended by the National Electrical Code or your local authority.

Reassembly of the Unit

1. With the unit now in place, loosen the 1/4 turn screws on the intake grille and allow the hinged portion to drop down.
2. Replace the prefilter screen, electronic cell, and carbon afterfilter, making sure to connect the grid cap connector to the cell. **REMOVE THE PLASTIC COVER FROM THE HEPA MEDIA BEFORE REINSTALLATION OF THE FILTER PAD.**
3. Close and lock the entire hinged panel into place.

Exhaust Grille Orientation

1. The exhaust grille side of your LAFC is equipped with individually movable louvers. To set them in the air pattern which best suits your needs, you simply angle them in the direction that you wish to direct the airflow.
2. A good pattern would allow for dispersion of the air so that it is not blowing straight down, perpendicular to the floor.

Start-Up and Checkout of the Unit

To make sure the unit is operating correctly before leaving the installation, please check the following:

1. Check all electrical connections and make sure they are tight and properly connected.
2. Electronic cell is in place and properly oriented so that the airflow arrow points in the direction of the airflow or the HEPA Media pad is properly oriented so that black carbon filter material is facing toward the ceiling.
3. Turn the unit on and check to see that it runs properly at all speeds. In addition, make sure the light goes on when the unit is in operation.
4. Open the intake grille section and check to see that the unit shuts off completely. Re-engage the panel and make sure unit turns on by watching light.

If for any reason the unit does not appear to work correctly, refer to the Troubleshooting Guide for assistance.

GENERAL INFORMATION:

Application

The Model LAFC should be mounted in the room or area where the air is to be cleaned. Removal of such pollutants as tobacco smoke and pollen from the air in areas like conference rooms, lounges, bingo halls, offices and the like is the goal of the unit. The LAFC provides its own air circulation and as such can be used for most applications requiring particulate removal.

Under no circumstances should the electronic Model LAFC be used in an atmosphere containing combustible gases or vapors. These applications are best served by the model HEPA LAFC.

Sizing

To size the air cleaner properly, one should know the volume of the room or area to be cleaned. Also, consider the use of the area so that the number of air changes per hour can be used in conjunction with the volume. Other considerations to be made may include:

- Ceiling height
- Type of pollutant to be removed
- Outside air quality
- How fast is the level of contamination rising
- What kind of air speed is anticipated

ASHRAE Standard 62-81 recommends several different air change formulas depending on the type of establishment to be ventilated.

Small offices, stores, homes	4-5 Air Changes/Hour
Computer rooms, waiting rooms, large offices, conference rooms	6-8 Air Changes/Hour
Beauty shops, cafeterias, bingo halls, bowling centers	10-12 Air Changes/Hour
Bars, lounges, discos, hospitals, casinos	12-15 Air Changes/Hour

LakeAir agrees in principle with this finding, but we have found that experience shows a slightly higher rate is needed than is indicated above.

To determine the number of LakeAir Model LAFC's needed in a given room, use the method below:

$$\frac{\text{Volume of Room (cu.ft.:LxWxH)} \times (\text{use \# from table above})}{60,000} = \text{Number of LAFC's}$$

The LAFC is capable of 400-1000 cfm. This multiplied by 60 minutes per hour yields the 60,000 figure above. It should be noted that this is an optimum figure and the other considerations above should be made before a final decision is reached. LakeAir can help you if necessary in making a good judgment.

**Proudly Made
in the U.S.A.**

MAINTENANCE

Washing the Electronic Cells and Prefilter

In order for your LakeAir Model LAFC to maintain peak operating efficiency, the prefilter screen and the electronic cells must be washed regularly. The frequency of this cleaning will depend on the atmosphere in which the units are operating. Recommendations for cleaning frequency can be obtained from your local LakeAir representative. The best way to clean the cells is by soaking them in hot water with LA-99 cell cleaning detergent (other methods can be used if time is a restraint).

1. Following the cell cleaner manufacture's instructions, add LA-99 cell cleaning solution or other detergent to hot water in an appropriate container such as a stationary tub.
2. Immerse the cell in the water and soak for 5 to 10 minutes. Then remove the cell and rinse with clean water, making sure to remove all residue from the cell surface.
3. Check cells for broken ion wires or bent plates and repair or replace if necessary.
4. Make sure the cell is completely dry before placing it back into the air cleaner.
5. Remove lint and other dirt from the prefilter by vacuuming or washing it in a mild detergent solution.

CAUTION: Care should be taken when handling the LAFC cells and filters.

1. Edges may be sharp on the collection plates as well as the area near the ionizing wires.
2. Be sure to wear appropriate gloves and goggles when dealing with a cell chemical of any kind. Contact with the skin is not recommended.
3. Electronic air cleaners and their components are susceptible to damage. Take care when working with them to avoid equipment damage.

Replacing the HEPA Media Pad

The HEPA Media pad cannot be cleaned and MUST BE REPLACED every 9-12 months. Failure to replace a heavily loaded filter can cause undue stress on the blower motors due to the reduced airflow and will void warranty. Contact your local LakeAir dealer to purchase replacement filters.

Service

Should your LakeAir LAFC malfunction, there are several simple checks which you can use to check the performance before a service person need be called.

1. Check to see if the fuse on the unit is tripped which would indicate electrical interruption to the unit. Correct by replacing fuse. If the circuit breaker or service box fuse is blown, that too will need replacement.
2. Be sure the electronic cell is in place and that the access door is locked down. Failure to have this done will cause the safety interlock to override the circuit.
3. If the operating light is not lit after checking these things, a service person should be consulted.

All electronic air cleaners undergo a process known as "arcing" from time to time. It is a snapping noise that comes from the electronic cell when very large particles enter into the collection cell or when the cells are wet or extremely dirty. If an unusual amount of arcing persists, check the collecting cells for broken wires, bent plates, or to see if they are very dirty. If arcing still occurs, check with your service person or dealer.

LakeAir MODEL LAFC

TROUBLESHOOTING GUIDE AND CHART

WARNING!!! The following instructions are intended for qualified service personnel only. Dangerous line voltage circuits are exposed during these procedures. Disconnect power at fuse before servicing the unit. Trouble shooting the LAFC can be accomplished with minimal tools and by following the directions given below in the two sections of Troubleshooting Guide. The first section deals with checks on determining the cause of a malfunction in your LAFC, and the second section explains how to find a faulty component, or how to determine that a specific component is functioning properly.

Diagnostic Checks

1. Powering up the LAFC

- a. Make sure the prefilter screen and electronic filter are clean, dry, and properly + installed in the air cleaner.
- b. Turn on the LAFC and check to make sure all systems are in proper working order. In each case, the system light should be on and the fan should run.
 - If the light does not come on, check the microswitch interlock for free movement as well at the power source for correct input.
 - If the fan does not come on, check the fan motor, wiring to the motor, and the power source.
 - If both the system light and the fan motor operate, go to step 2.
- c. **Test Technique**
- a. With the air cleaner turned on, use a long shank insulated screw driver to penetrate the pre filter screen and make contact with the electronic cell. A definite “snapping” sound and arcing should occur if the cell is properly energized.
- b. If no arcing is heard, check for continuity through the collector cell, then check for failure of the cell due to broken wires, cracked insulators, bent plates; and following that, a possible failure in the voltage doubler or transformer.
- d. **Cell Check**
- a. To remove the electronic cell from the unit, loosen the two quarter turn fasteners and allow the hinged intake to drop into place. Remove the grid cap connector from the cell and take the cell and pre filter from the unit.
- b. Close the hinged intake and check to see if the system light and the fan operate. If they do, check the cell for a short circuit.
- c. Replace the cell. If the Test Technique still does not produce a “snap” or arcing, go to step 4.
- e. **Check Power Supply**
- a. Remove the power supply from the LAFC cabinet and check for continuity through the circuit.
- b. Check continuity through the switch and go back through to the power source until the problem can be located.
- c. Replace the power supply into the cabinet and check for correct line voltage by powering up the system and using a voltmeter to measure the input voltage at the transformer.
- d. If voltage is correct (about 120V AC), then continue to check voltage at the secondary side of the transformer (2000V AC), and finally at the output (grid cap connector) which should yield about 6000V DC.
- e. Any variation from these voltages could indicate a component failure where replacement may be required.

Component Checks

1. Check Fan Motor and Power Source

If the fan does not run when the switch is on either in the *High* or *Low* position, check the voltage supplied to the motor.

1. If the motor does not turn when the proper voltage is supplied to it, check to see that the shaft turns freely. Replace the motor if necessary.
2. If the correct line voltage is not measured, check back through the wiring to the power source, including the interlock system.

2. Check the Electronic Cell

Visual Inspection – Carefully examine the electronic cell and look for the following:

- Bent plates
- Broken ionizing wires
- Dirt Accumulating on the cell plates
- Cracked or broken insulators

3. Check for Short Circuits

Use an ohmmeter to check resistance through the cell. Resistance should show an open circuit.

4. Check Transformer and Voltage Doubler (Electronic Units Only)

This check will locate a faulty component or connection in the power supply of your LAFC. **CAUTION!!! EXPOSURE TO LINE VOLTAGE IN THIS PROCEDURE WARRANTS SPECIAL CARE. BE SURE THE POWER IS TURNED OFF BEFORE CONNECTING OR DISCONNECTING ANY COMPONENT.**

1. Inspect power supply (transformer and doubler) for any physical signs of damage.
2. Turn the power off and connect voltage meter to the primary side of the high voltage transformer. Energize the system and check the line voltage.
3. Turn off the power, disconnect the primary side and reconnect to the secondary side of the transformer. A poor reading here will probably indicate a faulty transformer. Replacement is in order.
4. Turn off the power again, disconnect the transformer and connect to the output grid cap connector. Measure voltage (DC) at about 6000V open circuit. A poor measurement here should be traced back to the doubler in case of bad high voltage wire. If the reading is still poor at the doubler, it should be replaced.

TROUBLE SHOOTING FLOWCHART

The following trouble shooting procedure has been designed to speed the serviceman's work and insure that any malfunction in the electronic air cleaner is quickly and properly repaired. Refer first to flow chart below for an outline of the procedure, and then refer to the Troubleshooting Guide.

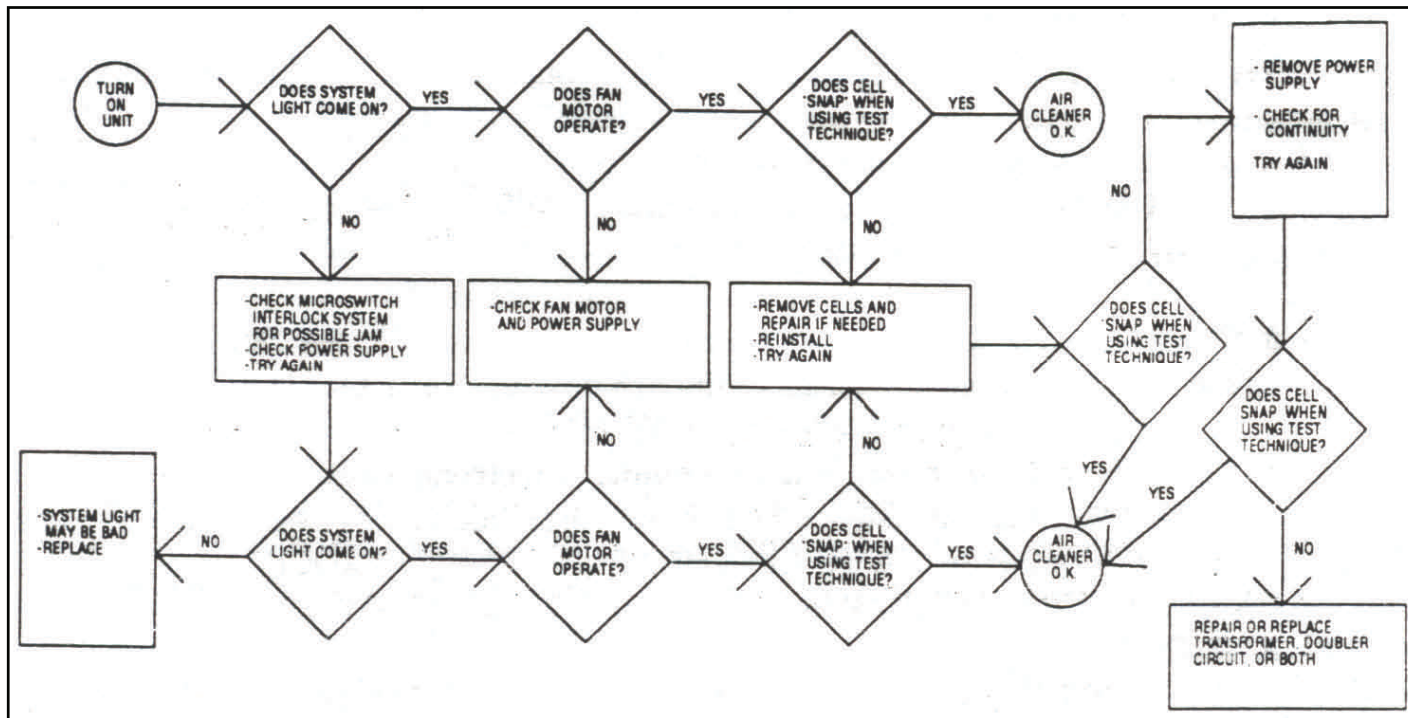

ELECTRICAL CONNECTIONS

ENERGIZED CONDUCTOR 115V POWER WIRE

BLUE OR BLACK WIRE FROM POWER SUPPLY IN LAFC

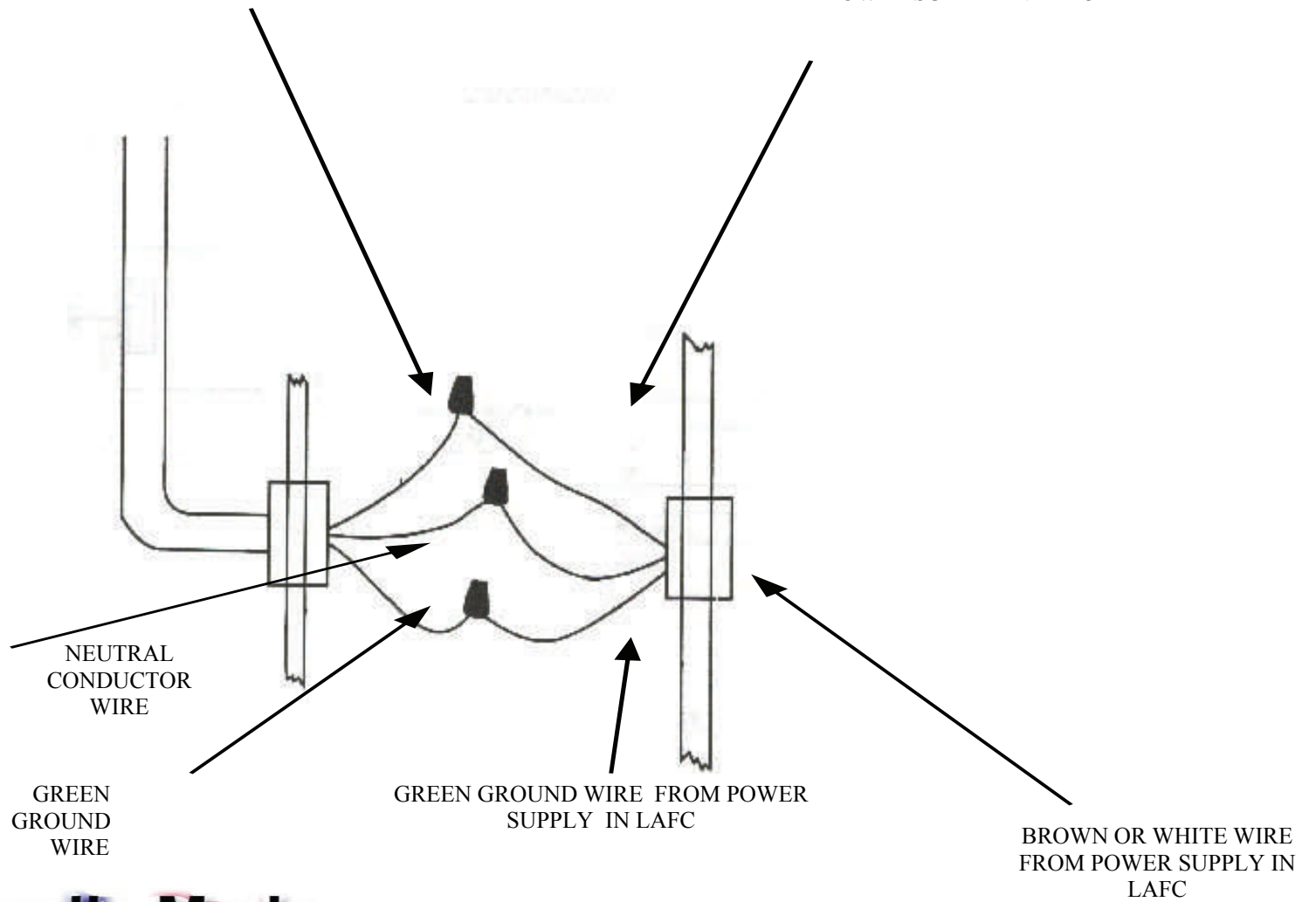

**Proudly Made
in the U.S.A.**

**ELECTRICAL SCHEMATIC
MODEL LAFC, 120V, 230V**

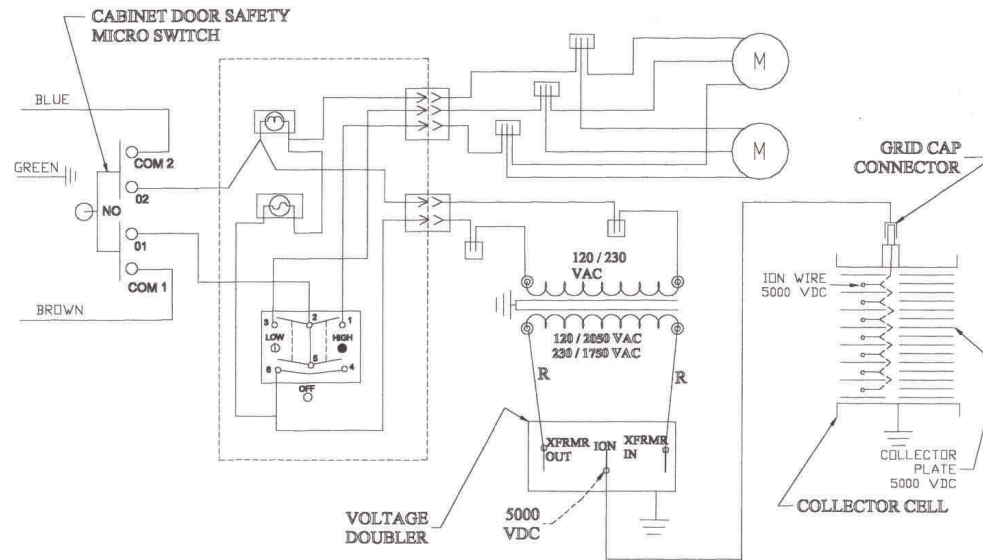

LAFC ELECTRONIC	120V	230V
SAFETY INTERLOCK MICRO SWITCH	497576	497567
ON/OFF SWITCH	497612	497612
MOTOR/BLOWER	497602	497609
FUSE	497547	497547
INDICATOR LAMP	497570	497592
POWER SUPPLY	10079	10179

MODEL LAFC PARTS SCHEMATIC

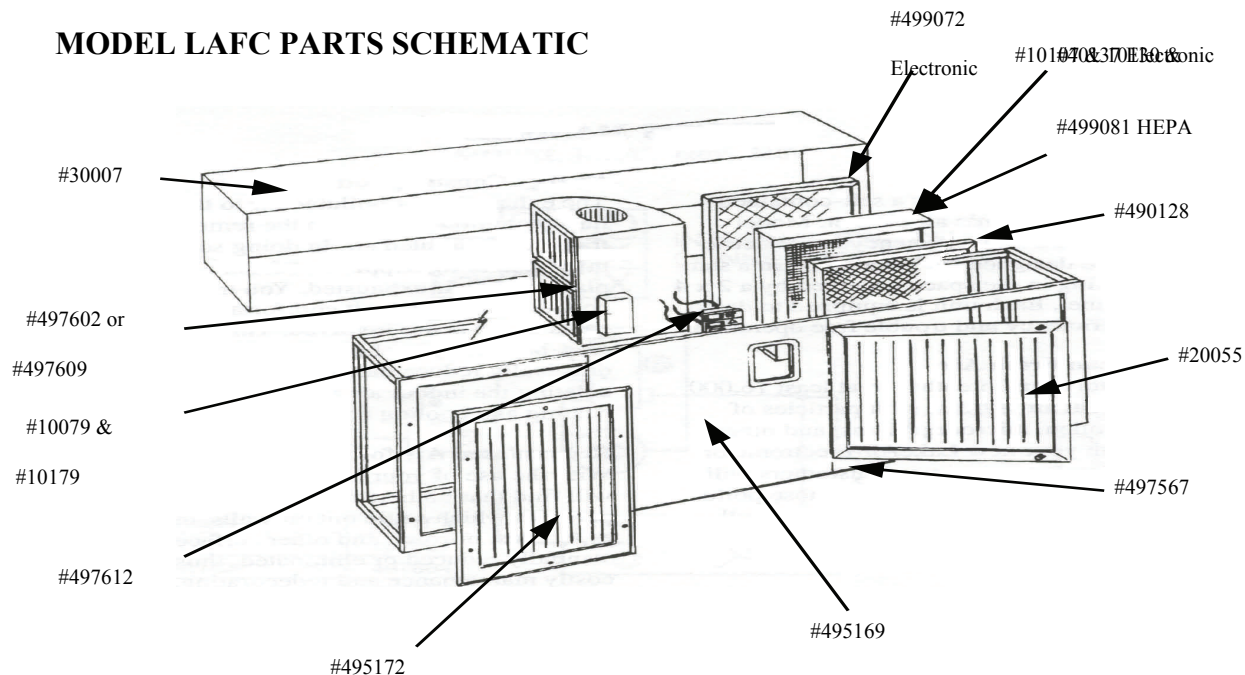

Part#	Description	Quantity Used
#10079	Complete Power Supply 120v (Electronic Only)	1
#10179	(contains 497606 Transformer & 497524 Voltage Quad) Complete Power Supply 230V (Electronic Only)	1
#10107	(contains 497607 Transformer & 497524 Voltage Quad) Complete Electronic Filter Cell (Electronic Only)	1
#10130	Ionizer Wire Kit (Electronic Only) - 6 each	1
#30007	LAFC Hood Assembly	1
#495169	Instrument Panel	1
#40137	Ceramic Stand-off Kit (Electronic Only)	1
#480029	Electrical Schematic Label	1
#490128	Prefilter Screen	1
#497567	Safety Interlock Micro-switch	1
#497602	Motor/Blower 120V(2-HEPA)	1
#497609	Motor/Blower 230V	1
#497612	Off/On Rocker Switch	1
#497547	Fuses	1
#499072	Carbon Afterfilter (for use with Electronic Filter Cell) HEPA Media pad	1
#499081	with integrated carbon filter	1

Other parts in the LAFC assembly can be obtained by calling or writing to LakeAir International Customer Service Department.

LakeAir International, Inc.
1509 Rapids Drive Racine,
Wisconsin 53404

Telephone 262/632-1229 Fax
262/632-3144 www.lakeair.com



LakeAir ELECTRONIC AIR CLEANERS 7 YEAR LIMITED WARRANTY

The Complete LakeAir Electronic or HEPA Air Cleaner is warranted by LakeAir International, Inc. to the original purchaser to be free from defects in material and workmanship under normal use and service for a period of one year from the date of purchase. In addition, LakeAir International, Inc. warrants the power supply module and transformer in the LakeAir Electronic Air Cleaner for an additional six (6) years or a total of seven (7) years from the date of purchase to the original purchaser. LakeAir's liability is to be limited to repairing or replacing such products during the warranty period at its option, providing the product is sent prepaid to LakeAir International, Inc. or an Authorized Service Center and is deemed to the satisfaction of LakeAir International, Inc. to be defective in any part or portion.

This warranty is in lieu of any other warranty expressed or implied and of all other obligations or liabilities in connection with the sale of the described LakeAir Electronic or HEPA Model Air Cleaners. In no case will any claim for consequential damages or labor expenses be allowed. This warranty does not apply to a LakeAir Electronic Air cleaner or any part thereof which has not been operated in accordance with the operating instructions herein contained; where components or other accessories not compatible with the LakeAir Electronic Air Cleaner have been used or attached to it; which has been subject to accident, unauthorized alteration, abuse, damage by flood, fire or acts of nature.

User's Responsibility

Please Note: Your warranty is subject to user responsibility. Some items and some conditions resulting from causes other than manufacturing defects are the responsibility of the user of the LakeAir Electronic or HEPA Air Cleaner and are not covered by the warranty. These are:

1. To operate and maintain according to instructions.
2. Periodic checking and cleaning of unit. Failure to clean or replace filters within the designated time spans will void warranty.
3. Proper use of controls must be maintained or warranty will be voided.
4. Damage to unit from unsatisfactory operation because of blowing fuses, inadequate electrical service or operation on power supply other than that indicated on the rating plate, or incorrect electrical protection devices used.
5. Damage occurring during transportation or resulting from improper handling.
6. Damage due to accident or resulting from alteration or tampering.
7. Misapplication of product.