



Portable electronic air cleaners

Operating and Service Manual Excel (120v)
Maxum (120v) Excel 230 (230v) Maxum 230 (230v)



RK Ventures Inc. 1509 Rapids Dr.
Racine, WI 53404

www.lakeair.com

DESCRIPTION OF PARTS

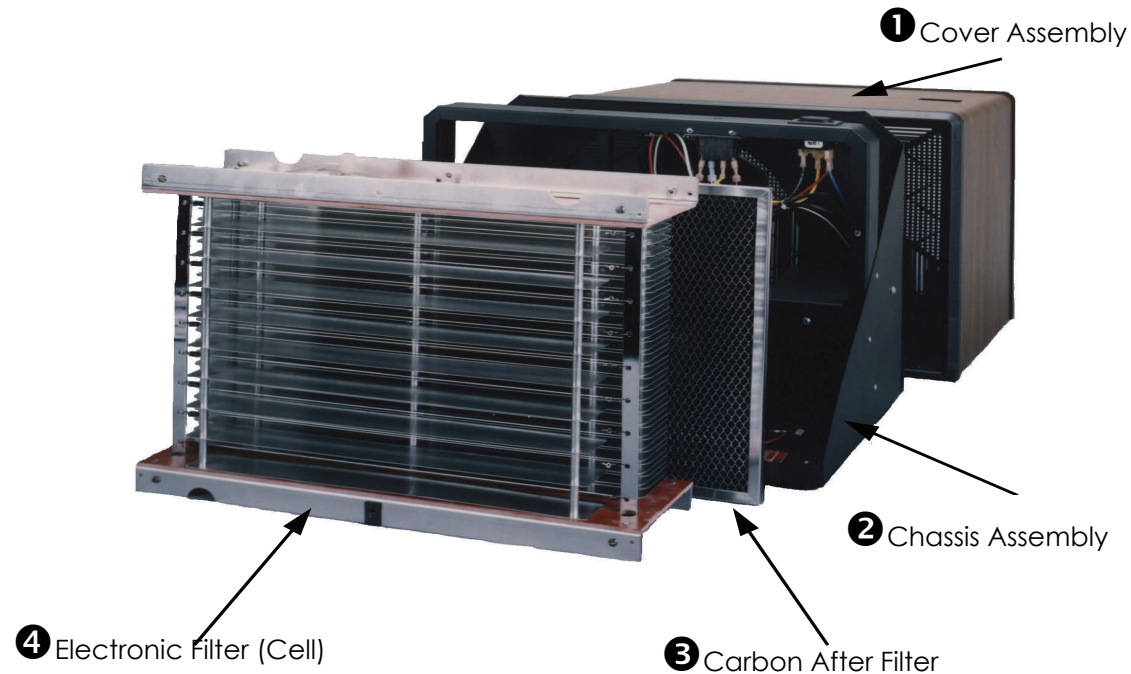

1. **COVER ASSEMBLY:** The vinyl covered metal cover assembly is secured to the chassis by means of two screw fasteners on top of the unit. The cover assembly includes the two grille sections.

2. **CHASSIS:** The chassis consists of the base of the Excel and Maxum and has several components of the unit attached to it. The motor and fan, power supply, control switch, and all internal wiring are found in the chassis.

3. **CARBON AFTERFILTER:** The carbon afterfilter is standard in all Excel and Maxum units and is used as an afterfilter to remove odors and VOCs from the cleaned air.

4. **ELECTRONIC FILTER (CELL):** This is the workhorse of the LakeAir Air Cleaner and performs the major function of the air cleaner by removing the particles from the air. The cell is activated by the power supply and is designed to remove even the smallest particles, down to 0.01 microns in size, or 1/25,400 of 1 inch.

HOW A LakeAir UNIT WORKS

In business establishments or in your home, millions of airborne particles are continually being circulated in the air you breathe. A LakeAir Electronic Air Cleaner removes these smoke, dust, dirt, and pollen particles with an electrostatic process that works this way:

1. The internal circulating fan draws the dirty air into the system where it first must pass through the outer grille.

2. The air then passes into the ELECTRONIC CELL where it encounters the IONIZING SECTION with its many fine ion wires. These wires charge the airborne particles by exciting them with a high electrical charge. As the charged particles move along to the collecting section, they are trapped by the collector plates much like a magnet attracts and collects metal filings.

3. The ACTIVATED CARBON AFTER FILTER, the final filter in the system, removes odors and freshens the air.

4. The cleaned and purified air is then returned to the room environment.

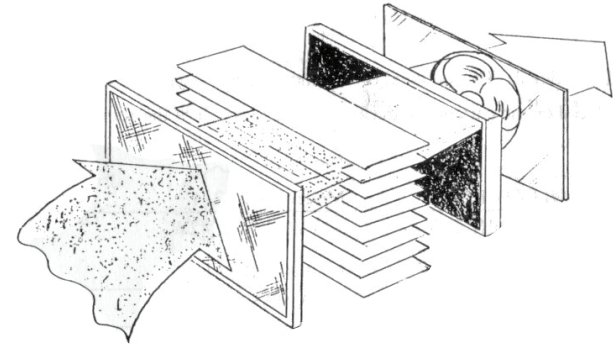

SPECIFICATIONS

	EXCEL	EXCEL 230	MAXUM	MAXUM 230
Input Voltages:	120v 60 Hz 72 Watts	230v 50 Hz 72 Watts	120v 60 Hz 102 Watts	230v 50 Hz 102 Watts
Cleaning Capacity:	Low: 70 cfm High: 110 cfm	Low: 21 m3/min. High: 34 m3/min.	Low: 210 cfm High: 275 cfm	Low: 65 m3/min. High: 85 m3/min.
Actual Size:	17" x 8" x 15"	43cm x 20cm x 38	17" x 13" x 15"	43cm x 33cm x 38cm
Actual Weight:	17lbs.	7.7 kg	24 lbs.	10.9kg
Shipping Size:	18" x 9" x 15"	48cm x 30cm x 38cm	18: x 15" X 16"	49cm x 38cm x 41cm
Shipping Weight:	22 lbs.	9.9 kg	29 lbs.	13.2 kg

UNPACKING AND OPERATING INSTRUCTIONS

In order to operate your LakeAir Air Cleaner properly, it is necessary to remove plastic packing material from the carbon afterfilter inside the unit. Follow the step-by-step instructions and you will soon be enjoying clean fresh air.

1. Remove the two thumb screws from the top of the cabinet.
2. Lift the cover assembly from the chassis and set aside.
3. Remove the carbon after filter from behind the cell. Take off the protective packing material and discard if there is any. Some units are shipped without filter bag
4. Replace the carbon after filter, then the cover assembly, making sure to include both of the fasteners. NOTE: The fasteners must be in place and secured snugly or the unit will not operate.

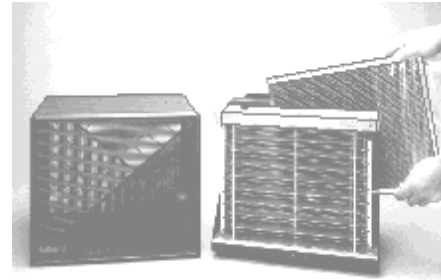

Place your LakeAir Air Cleaner in a convenient area in the desired room. If you are using the air cleaner for a specific purpose, such as smoke removal, locate the air cleaner as close as possible to the source. (Such as near a smoking stand.) Care should be taken to allow at least 4-6" of unobstructed space behind the unit so that it will exhaust freely into the room. If, however, you position the unit so that the airflow is parallel to the nearest wall, you need not allow as much free space. For best results the unit should be elevated by placing it on a table or stand. It can also be mounted on a wall, using our convenient wall mount option.

Plug the line cord into a standard household outlet with 120V AC 60 Hz (230 models require 230 V AC 50 Hz). Caution should be taken to use the unit only on the required voltage, as to do otherwise will void the warranty.

OPERATING AND MAINTENANCE INSTRUCTIONS

Position the unit and plug it into the proper line voltage before turning it on.

1. To turn unit on, locate the three-position rocker switch on top of the unit. Depress the button to activate the unit on the desired speed; *High*, *Low*, or *Off* (center, flat position). Under normal conditions, the *Low* position is adequate to keep an average size room clean. With excessive amounts of dust, smoke, or other pollutants present, the air cleaner should be operated on high.

**Proudly Made
in the U.S.A.**

2. To shut the unit off, simply push the button to its center (flat) position and unplug the unit from the line voltage.

NOTE: It should be noted that occasionally a large particle will pass through the electronic cell and an arcing will occur, resulting in an audible cracking sound. This is normal and will not cause any damage to the unit.

Maintenance

Your LakeAir Air Cleaner is a high quality, precision piece of equipment designed for long years of satisfactory performance. Adhere to a regular maintenance schedule and no problems should occur. This unit should be checked periodically for “dust load” and cleaned if found to have a large accumulation of dust and lint. Under regular conditions cleaning can be done once every 1 or 2 months. Under other more severe conditions more frequent cleaning may be required. **To obtain maximum efficiency from your LakeAir Electronic Air Cleaner it must be kept clean.**

In addition to the grilles and electronic cell, care should be taken to keep the rest of the unit clean as well.

Disassembly and Cleaning

1. Turn off unit and disconnect line cord from outlet.
2. Remove fasteners from cover assembly.
3. Lift cover from chassis.
4. Remove ground screw from base of chassis connecting chassis to the electronic cell. Lift cell from chassis, being careful not to bend any of the plates on the electronic cell.
5. The electronic cell may be cleaned in a number of ways, but the best way is to soak it in a container of hot water into which has been dissolved a cup of dishwasher detergent or other cleaner that is safe for aluminum. After soaking for 10-15 minutes, agitate the filter (cell) in the solution to release some of the particles. Alkaline cleaners, such as our LA-99 heavy duty cleaning solution, may be used with care. Be certain to read and follow all directions carefully to avoid damage to the aluminum cell components caused by harsh chemical agents. LA-99 can be obtained through your dealer or by calling LakeAir directly.
6. It may be necessary, if the cell is extremely dirty, to repeat the soaking process or to take a small soft brush to the plates of the cell.

If this is done, care should be taken not to damage the plates or the fine ion wires between the widely spaced plates on the ionizer section of the cells. After soaking, rinse off all traces of the detergent with clean warm water and allow the excess to drain off. Before replacing the cell into the chassis, make sure the cell is completely dry.

7. The electronic cell may also be washed in the normal cycle of a household dishwasher, but caution should be taken to avoid damage to the closely spaced plates of the unit.
8. Do not wash the carbon afterfilter. This filter should be brushed or cleaned with a vacuum cleaner if any dust is present. This filter should also be replaced when there is an indication that it is no longer absorbing odors. Normal replacement is approximately every 4-6 months.

NOTE: TO INSURE PROPER OPERATION, FILTERS SHOULD BE CLEANED AT REGULAR INTERVALS. FAILURE TO CLEAN ELECTRONIC FILTER WILL VOID WARRANTY.

Reassembly

1. Place the dry electronic filter (cell) back on the chassis, making sure the wider spaced plates (ionizer section) face the outside of the unit. Also make sure the handle is at the top of the unit.
2. Insert the ground screw in the proper location and tighten.
3. Place the carbon afterfilter back into the unit.
4. Replace the cover assembly and secure with the fasteners.
5. Before plugging the unit in, make sure the power button is in the *Off* position. Plug in the line cord and turn the unit on to the *High* or *Low* position. If arcing occurs, turn the unit off until the electronic filter cell has been dried completely.

TROUBLESHOOTING YOUR LakeAir ELECTRONIC AIR CLEANER

Some of the common causes for malfunction of your air cleaner are listed below. Re-view them should you have a problem, and perform the corrective measures listed here. If your LakeAir Electronic Air Cleaner is not restored to proper operation, contact your Dealer, nearest Authorized Service Center, or LakeAir.

Problem	Possible Cause	Possible Remedy
Air cleaner will not operate	Control switch is in <i>Off</i> Position	Depress power switch to <i>High</i> or <i>Low</i>
	Power cord not plugged in	Plug in power cord
	Blown fuse in household or breaker tripped.	Replace fuse or reset breaker
	Cover removed Cover fasteners not tight	Replace cover Tighten fasteners snugly
Small volume of air discharged from unit	Extremely dirty electronic filter (cell)	Clean according to Instructions
	Plastic packing still on carbon after filter	Remove plastic wrap
Unit not effectively cleaning the air	Electronic filter dirty	Clean according to Instructions
	Electronic filter is not prop-erly installed	Check reassemble instructions
Continuous “arcing” or snap-ping noise	Excessive accumulation of dirt on the electronic filter	Clean according to Instructions
	Electronic filter still damp	Allow filter cell to dry Com-pletely
	Bent or damaged plate on electronic filter. (cell)	Check and straighten
Odors more pronounced than usual	Service life of carbon after filter expired	Discard and replace the carbon after filter
	Air cleaner being used in a confined space	Open doors to the adjoining rooms

If any of the problems are not solved to your satisfaction, please contact your Dealer or LakeAir

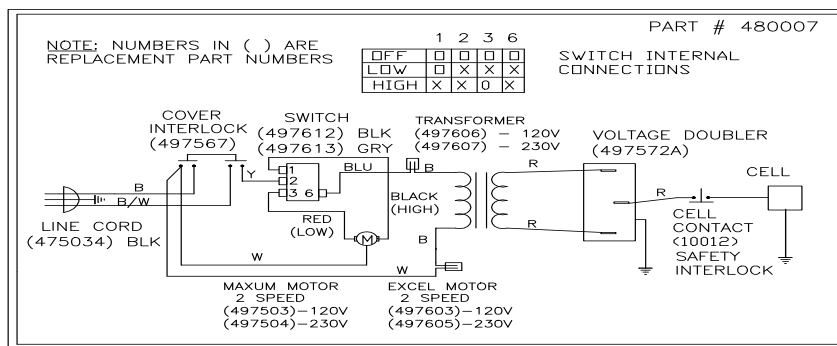
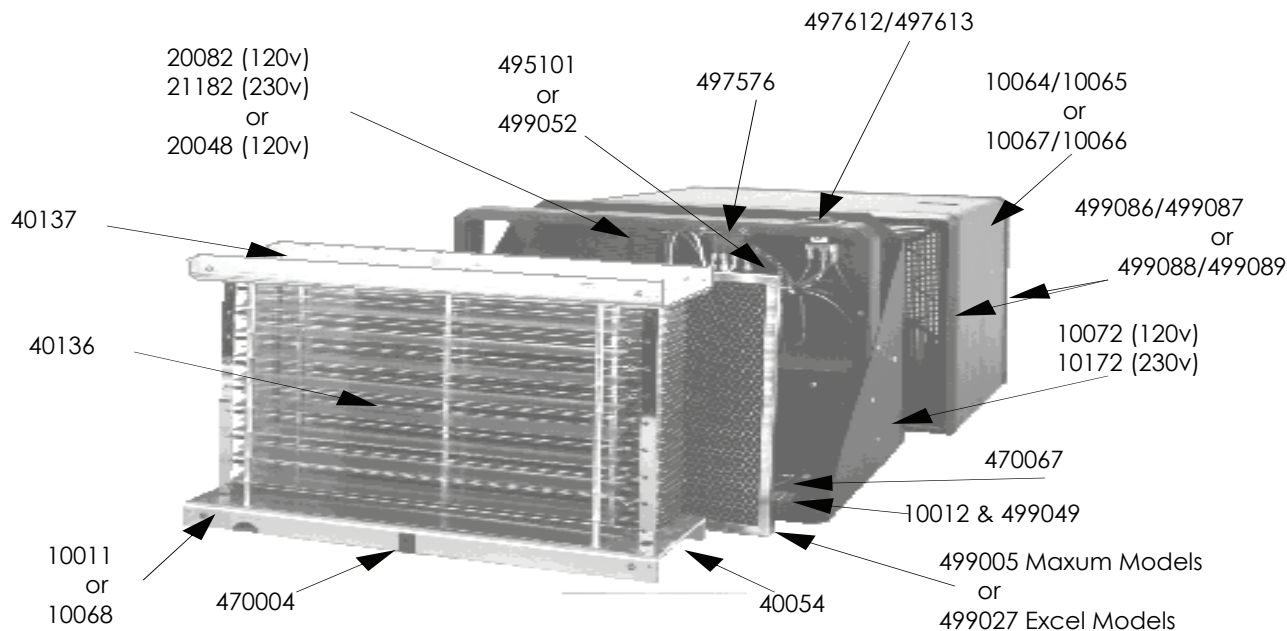

EXCEL PARTS

Part#	Description
10068	Electronic Filter Cell
499027	Carbon Afterfilter
10066	Cover Assembly-Woodgrain
10067	Cover Assembly-White
20082	Motor 120v
21182	Motor, 230v
499052	Fan Blade 499086
499087	Grille, Black
499089	Grille, Grey

MAXUM PARTS

Part#	Description
10011	Electronic Filter Cell
499005	Carbon Afterfilter
10064	Cover Assembly-Woodgrain
10065	Cover Assembly-White
20048	Motor, 120v
21148	Motor, 230v
495101	Fan Blade 499088
499089	Grille, Black
499087	Grille, Grey

PARTS COMMON TO BOTH UNITS

10012&499049	Cell Contact Bracket	40054	Ion Connector Strap
470004	Ground Screw	U-Clip	
497572A	Voltage Doubler		
497606	Transformer 120v		
497607	Transformer 230v		
40136	Ion Wires w/S-Hooks and Springs (6)	40137	Ceramic Insulators w/Screws (4/8)
470067	High Voltage Wire	Jiffy Clip	
470033	Black cover	Fastener	
495159	White Cover	Fastener	
497613	Grey	Rocker Switch	
497612	Black	Rocker Switch	

LakeAir ELECTRONIC AIR CLEANERS 7 YEAR LIMITED WARRANTY

The complete LakeAir Electronic Air Cleaner is warranted by LakeAir International, Inc. to the original purchaser to be free from defects in material and workmanship under normal use and service for a period of one year from the date of purchase. In addition, LakeAir International, Inc. warrants the power supply module and transformer in the LakeAir Electronic Air Cleaner for an additional six (6) years, or a total of seven (7) years from the date of purchase to the original purchaser. LakeAir's liability is to be limited to repairing or replacing such products during the warranty period at its option, providing the product is sent prepaid to LakeAir International, Inc. or an Authorized Service Center and is deemed to the satisfaction of LakeAir International, Inc. to be defective in any part or portion.

This warranty is in lieu of any other warranty expressed or implied and of all other obligations or liabilities in connection with the sale of the described LakeAir Electronic Air Cleaner. In no case will any claim for consequential damages or labor expenses be allowed. This warranty does not apply to a LakeAir Electronic or any part thereof which has not been operated in accordance with the operating instructions herein contained; where components or other accessories not compatible with the LakeAir Electronic Air Cleaner have been used or attached to it; which has been subject to accident, unauthorized alteration, abuse, damage by flood, fire or acts of nature.

User's Responsibility

Please Note: Your warranty is subject to user responsibility. Some items and some conditions resulting from causes other than manufacturing defects are the responsibility of the user of the LakeAir Electronic Air Cleaner and are not covered by the warranty. These are:

1. To operate and maintain according to instructions.
2. Periodic checking and cleaning of unit. Failure to clean will void warranty.
3. Proper use of controls must be maintained or warranty will be voided.
4. Damage to unit from unsatisfactory operation because of blowing fuses, inadequate electrical service or operation on power supply other than that indicated on the rating plate, or incorrect electrical protection devices used.
5. Damage occurring during transportation or resulting from improper handling.
6. Damage due to accident or resulting from alteration or tampering.
7. Misapplication of product.



RK Ventures Inc. 1509 Rapids Drive
Racine, Wisconsin 53404